

NEET UG 2013

- The following four wires are made of the same material. Which of these will have the largest extension when the same tension is applied ?
 (1) length = 300cm, diameter = 3mm
 (2) length = 50 cm, diameter = 0.5 mm
 (3) length = 100 cm, diameter = 1mm
 (4) length = 200 cm, diameter = 2mm
- The wettability of a surface by a liquid depends primarily on :-
 (1) angle of contact between the surface and the liquid
 (2) viscosity
 (3) surface tension
 (4) density

AIPMT 2014

- Copper of fixed volume 'V'; is drawn into wire of length ' ℓ '. When this wire is subjected to a constant force 'F', the extension produced in the wire is ' $\Delta\ell$ '. Which of the following graphs is a straight line ?
 (1) $\Delta\ell$ versus $\frac{1}{\ell}$ (2) $\Delta\ell$ versus ℓ^2
 (3) $\Delta\ell$ versus $\frac{1}{\ell^2}$ (4) $\Delta\ell$ versus ℓ
- A certain number of spherical drops of a liquid of radius 'r' coalesce to form a single drop of radius 'R' and volume 'V'. If 'T' is the surface tension of the liquid, then :
 (1) energy = $4VT \left(\frac{1}{r} - \frac{1}{R} \right)$ is released
 (2) energy = $3VT \left(\frac{1}{r} + \frac{1}{R} \right)$ is absorbed
 (3) energy = $3VT \left(\frac{1}{r} - \frac{1}{R} \right)$ is released
 (4) Energy is neither released nor absorbed

AIPMT 2015

- The approximate depth of an ocean is 2700 m. The compressibility of water is $45.4 \times 10^{-11} \text{ Pa}^{-1}$ and density of water is 10^3 kg/m^3 . What fractional compression of water will be obtained at the bottom of the ocean ?
 (1) 1.0×10^{-2} (2) 1.2×10^{-2}
 (3) 1.4×10^{-2} (4) 0.8×10^{-2}

- A wind with speed 40 m/s blows parallel to the roof of a house. The area of the roof is 250 m². Assuming that the pressure inside the house is atmospheric pressure, the force exerted by the wind on the roof and the direction of the force will be:
 ($\rho_{\text{air}} = 1.2 \text{ kg/m}^3$)
 (1) $4.8 \times 10^5 \text{ N}$, upwards
 (2) $2.4 \times 10^5 \text{ N}$, upwards
 (3) $2.4 \times 10^5 \text{ N}$, downwards
 (4) $4.8 \times 10^5 \text{ N}$, downwards

Re-AIPMT 2015

- The cylindrical tube of a spray pump has radius R, one end of which has n fine holes, each of radius r. If the speed of the liquid in the tube is V, the speed of the ejection of the liquid through the holes is :-
 (1) $\frac{V^2R}{nr}$ (2) $\frac{VR^2}{n^2r^2}$
 (3) $\frac{VR^2}{nr^2}$ (4) $\frac{VR^2}{n^3r^2}$
- The Young's modulus of steel is twice that of brass. Two wires of same length and of same area of cross section, one of steel and another of brass are suspended from the same roof. If we want the lower ends of the wires to be at the same level, then the weights added to the steel and brass wires must be in the ratio of :
 (1) 1 : 1 (2) 1 : 2 (3) 2 : 1 (4) 4 : 1
- Water rises to height 'h' in capillary tube. If the length of capillary tube above the surface of water is made less than 'h', then -
 (1) water does not rise at all.
 (2) water rises upto the tip of capillary tube and then starts overflowing like a fountain.
 (3) water rises upto the top of capillary tube and stays there without overflowing.
 (4) water rises upto a point a little below the top and stays there.
- The heart of a man pumps 5 litres of blood through the arteries per minute at a pressure of 150 mm of mercury. If the density of mercury be $13.6 \times 10^3 \text{ kg/m}^3$ and $g = 10 \text{ m/s}^2$ then the power of heart in watt is:
 (1) 1.50 (2) 1.70
 (3) 2.35 (4) 3.0

NEET-I 2016

11. Two non-mixing liquids of densities ρ and $n\rho$ ($n > 1$) are put in a container. The height of each liquid is h . A solid cylinder of length L and density d is put in this container. The cylinder floats with its axis vertical and length pL ($p < 1$) in the denser liquid. The density d is equal to :-
- (1) $\{1 + (n + 1)p\}\rho$ (2) $\{2 + (n + 1)p\}\rho$
 (3) $\{2 + (n - 1)p\}\rho$ (4) $\{1 + (n - 1)p\}\rho$

NEET-II 2016

12. A rectangular film of liquid is extended from $(4 \text{ cm} \times 2 \text{ cm})$ to $(5 \text{ cm} \times 4 \text{ cm})$. If the work done is $3 \times 10^{-4} \text{ J}$, the value of the surface tension of the liquid is :-
- (1) 0.2 Nm^{-1} (2) 8.0 Nm^{-1}
 (3) 0.250 Nm^{-1} (4) 0.125 Nm^{-1}
13. Three liquids of densities ρ_1, ρ_2 and ρ_3 (with $\rho_1 > \rho_2 > \rho_3$), having the same value of surface tension T , rise to the same height in three identical capillaries. The angles of contact θ_1, θ_2 and θ_3 obey:-
- (1) $\frac{\pi}{2} < \theta_1 < \theta_2 < \theta_3 < \pi$
 (2) $\pi > \theta_1 > \theta_2 > \theta_3 > \frac{\pi}{2}$
 (3) $\frac{\pi}{2} > \theta_1 > \theta_2 > \theta_3 \geq 0$
 (4) $0 \leq \theta_1 < \theta_2 < \theta_3 < \frac{\pi}{2}$

NEET(UG) 2017

14. The bulk modulus of a spherical object is 'B'. If it is subjected to uniform pressure 'p', the fractional decrease in radius is :-
- (1) $\frac{B}{3p}$ (2) $\frac{3p}{B}$ (3) $\frac{p}{3B}$ (4) $\frac{p}{B}$
15. A U tube with both ends open to the atmosphere, is partially filled with water. Oil, which is immiscible with water, is poured into one side until it stands at a distance of 10 mm above the water level on the other side. Meanwhile the water rises by 65 mm from its original level (see diagram). The density of the oil is :-

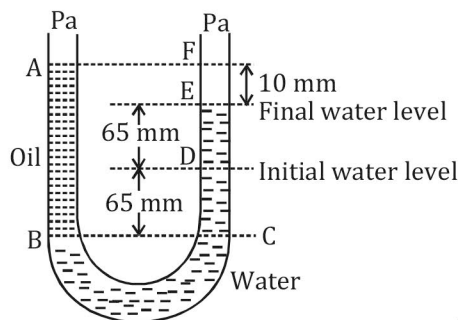

- (1) 425 kg m^{-3} (2) 800 kg m^{-3}
 (3) 928 kg m^{-3} (4) 650 kg m^{-3}

NEET(UG) 2018

16. A small sphere of radius 'r' falls from rest in a viscous liquid. As a result, heat is produced due to viscous force. The rate of production of heat when the sphere attains its terminal velocity, is proportional to :-
- (1) r^3 (2) r^2 (3) r^5 (4) r^4
17. Two wires are made of the same material and have the same volume. The first wire has cross-sectional area A and the second wire has cross-sectional area $3A$. If the length of the first wire is increased by Δl on applying a force F , how much force is needed to stretch the second wire by the same amount ?
- (1) $9F$ (2) $6F$ (3) $4F$ (4) F

NEET(UG) 2019

18. A soap bubble, having radius of 1 mm, is blown from a detergent solution having a surface tension of $2.5 \times 10^{-2} \text{ N/m}$. The pressure inside the bubble equals at a point Z_0 below the free surface of water in a container. Taking $g = 10 \text{ m/s}^2$ density of water = 10^3 kg/m^3 , the value of Z_0 is :-
- (1) 100 cm (2) 10 cm
 (3) 1 cm (4) 0.5 cm
19. When a block of mass M is suspended by a long wire of length L , the length of the wire become $(L+l)$. The elastic potential energy stored in the extended wire is :-
- (1) Mgl (2) MgL
 (3) $\frac{1}{2} Mgl$ (4) $\frac{1}{2} MgL$

20. A small hole of area of cross-section 2 mm^2 is present near the bottom of a fully filled open tank of height 2 m. Taking $g = 10 \text{ m/s}^2$, the rate of flow of water through the open hole would be nearly :

- (1) $12.6 \times 10^{-6} \text{ m}^3/\text{s}$ (2) $8.9 \times 10^{-6} \text{ m}^3/\text{s}$
 (3) $2.23 \times 10^{-6} \text{ m}^3/\text{s}$ (4) $6.4 \times 10^{-6} \text{ m}^3/\text{s}$

NEET(UG) 2019 (Odisha)

21. Two small spherical metal balls, having equal masses, are made from materials of densities ρ_1 and ρ_2 ($\rho_1 = 8\rho_2$) and have radii of 1mm and 2mm, respectively. They are made to fall vertically (from rest) in a viscous medium whose coefficient of viscosity equals η and whose density is $0.1 \rho_2$. The ratio of their terminal velocities would be :-

- (1) $\frac{79}{72}$ (2) $\frac{19}{36}$ (3) $\frac{39}{72}$ (4) $\frac{79}{36}$

22. In a U-tube as shown in figure, water and oil are in the left side and right side of the tube respectively. The heights from the bottom for water and oil columns are 15 cm and 20 cm respectively. The density of the oil is :-
 [take $\rho_{\text{water}} = 1000 \text{ kg/m}^3$]

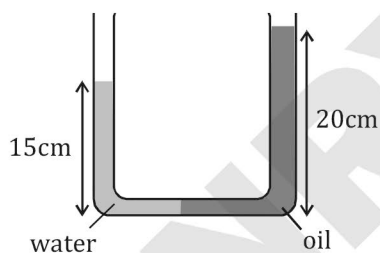

- (1) 1200 kg/m^3 (2) 750 kg/m^3
 (3) 1000 kg/m^3 (4) 1333 kg/m^3

23. The stress-strain curves are drawn for two different materials X and Y. It is observed that the ultimate strength point and the fracture point are close to each other for material X but are far apart for material Y. We can say that materials X and Y are likely to be (respectively)

- (1) ductile and brittle
 (2) brittle and ductile
 (3) brittle and plastic
 (4) plastic and ductile

NEET (UG) 2020

24. A capillary tube of radius r is immersed in water and water rises in it to a height h . The mass of the water in the capillary is 5g. Another capillary tube of radius $2r$ is immersed in water. The mass of water that will rise in this tube is :

- (1) 20.0 g (2) 2.5 g
 (3) 5.0 g (4) 10.0 g

25. A wire of length L , area of cross section A is hanging from a fixed support. The length of the wire changes to L_1 when mass M is suspended from its free end. The expression for Young's modulus is :

- (1) $\frac{MgL}{A(L_1 - L)}$ (2) $\frac{MgL_1}{AL}$
 (3) $\frac{Mg(L_1 - L)}{AL}$ (4) $\frac{MgL}{AL_1}$

NEET (UG) 2020 (Covid-19)

26. A liquid does not wet the solid surface if angle of contact is :

- (1) equal to 45°
 (2) equal to 60°
 (3) greater than 90°
 (4) zero

27. A barometer is constructed using a liquid (density = 760 kg/m^3). What would be the height of the liquid column, when a mercury barometer reads 76 cm ?
 (density of mercury = 13600 kg/m^3)

- (1) 1.36 m (2) 13.6 m
 (3) 136 m (4) 0.76 m

NEET (UG) 2021

28. The velocity of a small ball of mass M and density d , when dropped in a container filled with glycerine becomes constant after some time. If the density of glycerine is $\frac{d}{2}$, then the viscous force acting on the ball will be :

- (1) $\frac{Mg}{2}$ (2) Mg
 (3) $\frac{3}{2}Mg$ (4) $2Mg$

NEET (UG) 2022

29. A spherical ball is dropped in a long column of a highly viscous liquid. The curve in the graph shown, which represents the speed of the ball (v) as a function of time (t) is :

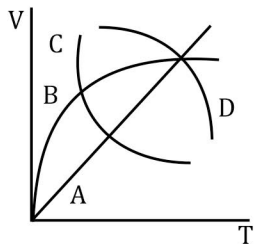

- (1) B (2) C (3) D (4) A

30. If a soap bubble expands, the pressure inside the bubble :

- (1) increases
 (2) remains the same
 (3) is equal to the atmospheric pressure
 (4) decreases

RE-NEET (UG) 2022

31. Two copper vessels A and B have the same base area but of different shapes. A takes twice the volume of water as that B requires to fill upto a particular common height. Then the correct statement among the following is:

- (1) Pressure on the base area of vessels A and B is same.
 (2) Pressure on the base area of vessels A and B is not same.
 (3) Both vessels A and B weigh the same.
 (4) Vessel B weighs twice that of A.

32. The terminal velocity of a copper ball of radius 5 mm falling through a tank of oil at room temperature is 10 cm s^{-1} . If the viscosity of oil at room temperature is $0.9 \text{ kg m}^{-1} \text{ s}^{-1}$, the viscous drag force is :

- (1) $8.48 \times 10^{-3} \text{ N}$ (2) $8.48 \times 10^{-5} \text{ N}$
 (3) $4.23 \times 10^{-3} \text{ N}$ (4) $4.23 \times 10^{-6} \text{ N}$

EXERCISE-II (Previous Year Questions)

ANSWER KEY

Question	1	2	3	4	5	6	7	8	9	10	11	12	13	14	15
Answer	2	1	2	3	2	2	3	3	3	2	4	4	4	3	3
Question	16	17	18	19	20	21	22	23	24	25	26	27	28	29	30
Answer	3	1	3	3	1	4	2	2	4	1	3	2	1	1	4
Question	31	32													
Answer	1	1													